

# 10Gb/s SFP+ CWDM 10km Transceiver

## LA-OT-10G-CW26-10

### Features

- SFP+ package with LC connector
- DML CWDM DFB Laser and PIN-TIA photodetector
- Up to 10Km transmission on SMF
- Up to 11.3Gbps Data Links
- +3.3V single power supply
- Power dissipation<1.5W
- 2-wire interface with integrated Digital Diagnostic monitoring
- Low EMI and excellent ESD protection
- laser safety standard IEC-60825 compliant
- Compatible with RoHS
- Compliant with SFF-8472 SFP+ MSA
- Compliant to SFP+ SFF-8431 and SFF-8432

### Application

- Ethernet
- Telecom
- Fiber Channel

### Absolute Maximum Ratings

Parameter	Symbol	Minimum	Maximum	Units
Storage Temperature	Tst	-40	+85	°C
Supply Voltage	Vcc	-0.3	+3.5	V
Operating Relative Humidity	RH	5	95	%

## Operation Environment

Parameter	Symbol	Min	Typical	Max	Units
Supply Voltage	Vcc	3.15	3.3	3.45	V
Operating Case Temperature	Tc	0		+70	°C
Power Dissipation				1.5	W
Data Rate			10.3125		Gbps

## Optical Characteristics

Parameter	Symbol	Min.	Typ.	Max.	Units
<b>Transmitter Section</b>					
Center Wavelength	$\lambda_o$	1270		1610	nm
Spectral Width(-20dB)	$\Delta\lambda$			1	nm
Average Output Power	Po	-3		+5	dBm
Extinction Ratio	Er	3.5			dB
Side-Mode Suppression Ratio	SMSR	35			dB
Total jitter	Tj	IEEE 802.3ae			
<b>Receiver Section</b>					
Center Wavelength	$\lambda_o$	1270	1330	1610	nm
Receiver Sensitivity	Rsen			-13	dBm
Receiver Overload	Rov	0			dBm
Return Loss		12			dB
LOS Assert	LOS <sub>A</sub>	-28			dBm
LOS Dessert	LOS <sub>D</sub>			-14	dBm
LOS Hysteresis		0.5		4	

### Electrical Characteristics

Parameter	Symbol	Min.	Typ.	Max.	Unit
<b>Transmitter Section</b>					
Input Differential Impedence	Zin	90	100	110	Ohm
Data Input Swing Differential	Vin	180		700	mV
TX Disable	Disable	2.0		Vcc	V
	Enable	-0.3		0.8	V
TX Fault	Assert	2.4		Vcc	V
	Deassert	-0.3		0.8	V
<b>Receiver Section</b>					
Output differential impedence	Zout	80	100	120	Ohm
Data Input Swing Differential	Vout	300		850	mV
Rx_LOS	Assert	2.0		Vcc	V
	Deassert	-0.3		0.4	V

### Diagnostics

Parameter	Range	Accuracy	Unit	Calibration
Temperature	0 ~ 70	±5	°C	Internal
Voltage	3.15 ~ 3.45	±0.1	V	Internal
Bias Current	10 ~ 80	±2	mA	Internal
Tx Power	-5 ~ +5	±2	dBm	Internal
Rx Power	-16 ~ -3	±3	dBm	Internal

### Pin Description

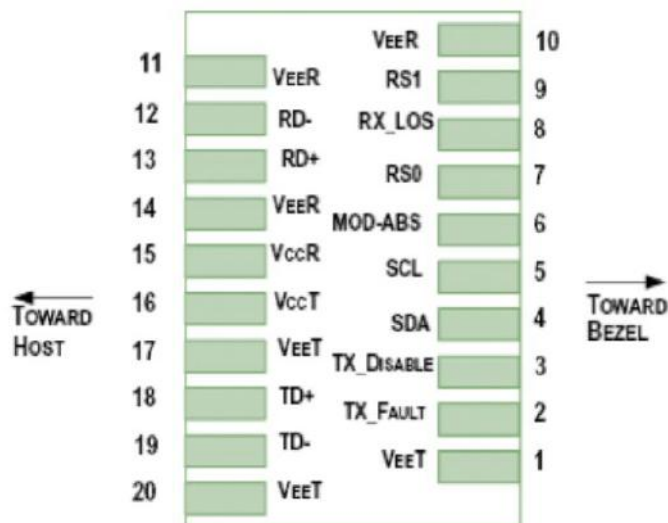

Pins	Name	Description	NOTE
1	VeeT	Transmitter Ground	
2	Tx Fault	Transmitter Fault Indication	1
3	Tx Disable	Transmitter Disable	2
4	MOD DEF2	Module Definition 2	3
5	MOD DEF1	Module Definition 1	3
6	MOD DEF0	Module Definition 0	3
7	RS0	Not Connected	
8	LOS	Loss of Signal	4
9	RS1	Not Connected	
10	VeeR	Receiver Ground	
11	VeeR	Receiver Ground	
12	RD-	Inv. Received Data Output	5
13	RD+	IReceived Data Output	5
14	VeeR	Receiver Ground	
15	VccR	Receiver Power	
16	VccT	Transmitter Power	
17	VeeT	Transmitter Ground	
18	TD+	Transmit Data Input	6
19	TD-	Inv. Transmit Data Input	6
20	VeeT	Transmitter Ground	

## Notes:

- TX Fault is an open collector output, which should be pulled up with a 4.7k~10kΩ resistor on the host board to a voltage between 2.0V and Vcc+0.3V. Logic 0 indicates normal operation; logic 1 indicates a laser fault of some kind. In the low state, the output will be pulled to less than 0.8V.
- TX Disable is an input that is used to shut down the transmitter optical output. It is pulled up within the module with a 4.7k~10kΩ resistor. Its states are:
  - Low (0~0.8V): Transmitter on
  - (>0.8V, <2.0V): Undefined
  - High (2.0~3.3V): Transmitter Disabled
  - Open: Transmitter Disabled
- MOD-DEF 0,1,2 is the module definition pins. They should be pulled up with a 4.7k~10kΩ resistor on the host board. The pull-up voltage shall be VccT or VccR.
  - MOD-DEF 0 is grounded by the module to indicate that the module is present
  - MOD-DEF 1 is the clock line of two wire serial interface for serial ID
  - MOD-DEF 2 is the data line of two wire serial interface for serial ID
- LOS is an open collector output, which should be pulled up with a 4.7k~10kΩ resistor on the host board to a voltage between 2.0V and Vcc+0.3V. Logic 0 indicates normal operation; logic 1 indicates loss of signal. In the low state, the output will be pulled to less than 0.8V.
- These are the differential receiver output. They are internally AC-coupled 100Ω differential lines which should be terminated with 100Ω (differential) at the user SERDES.
- These are the differential transmitter inputs. They are AC-coupled, differential lines with 100Ω differential termination inside the module.

### Recommended Application Circuit

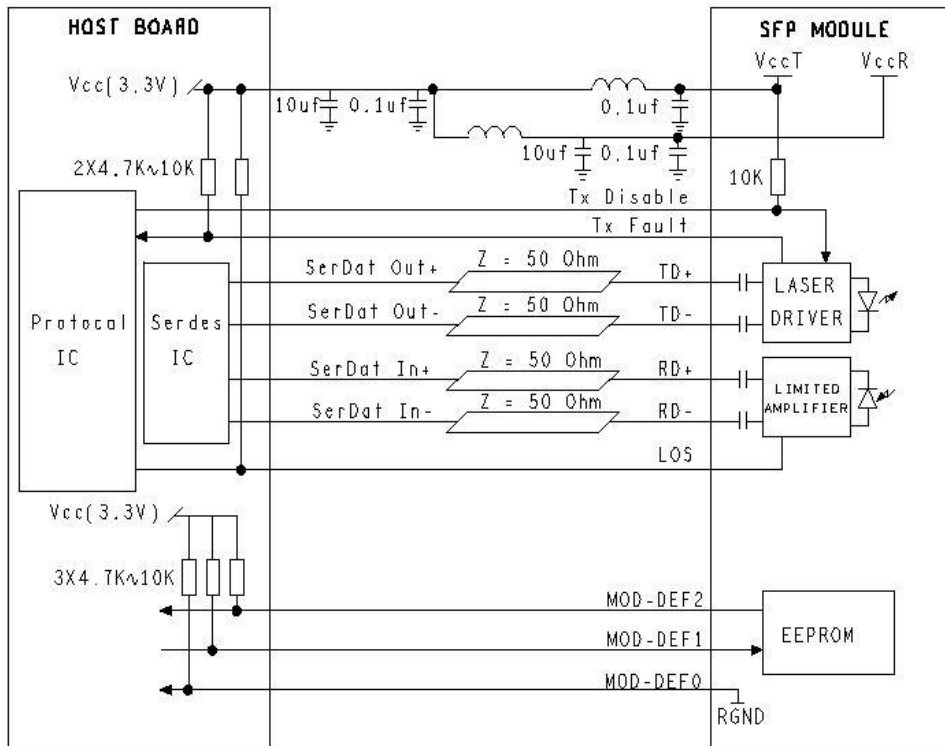

### Outline Drawings (mm)

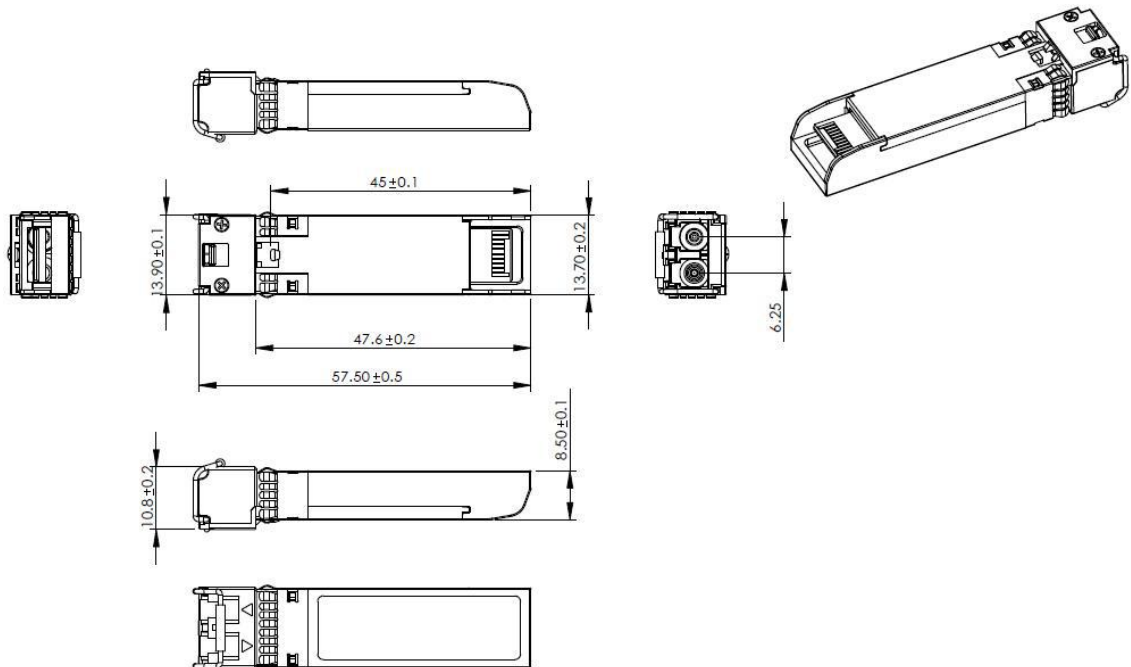



<https://www.lanaotek.com>



Specifications & design are subject to change without prior notice.

For more details, please email to [info@lanaotek.com](mailto:info@lanaotek.com). Copyright©2024 lanaotek.com All Rights Reserved