

100Gb/s CFP ER4 40km

LA-CFP-ER4/OTU4

Description

LA-CFP-ER4/OTU4, 100G CFP2 ER4 optical transceiver integrates the transmit and receive path onto one module. On the transmit side, four lanes of serial data streams are recovered, retimed, and passed on to four laser drivers, which control four electric-absorption modulated lasers (EMLs) with 1296, 1300, 1305, and 1309 nm center wavelengths. The optical signals are then multiplexed into a single-mode fiber through an industry-standard LC connector. On the receive side, 4 lanes of optical data streams are optically demultiplexed by an integrated optical demultiplexer. Each data stream is recovered by a PIN photodetector and transimpedance amplifier, retimed, and passed on to an output driver. This module features a hot-pluggable electrical interface, low power consumption, and MDIO management interface.

Features

- Supports 103.1Gbps to 112Gbps bit rates
- Duplex LC connector
- Hot pluggable
- 4x28Gb/s DFB-based LAN-WDM transmitter
- 10x10G MLD electrical interface
- Applicable for 40km SMF connection
- Low power consumption, < 18W
- Digital Diagnostic Monitor Interface
- MDIO Communication Interface
- Compliant with 100GBASE-ER4 and OTU4
- Operating case temperature: Commercial: 0 to 70 °C

Applications

- OTN OTU4
- 100GBASE-ER4 100G Ethernet
- Other Optical link

Functional Diagram

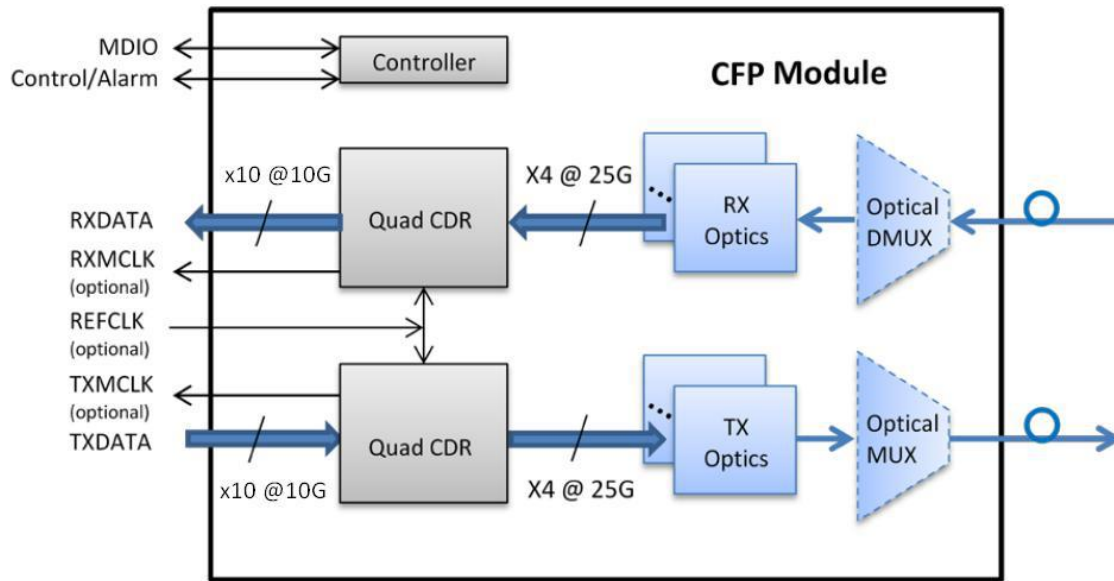

Absolute Maximum Ratings

Parameter	Symbol	Min.	Max.	Unit	Note
Supply Voltage	Vcc	-0.5	4.0	V	
Storage Temperature	TS	-40	85	°C	
Relative Humidity	RH	0	85	%	
Rx Damage Threshold, per Lane	PRdmg	5.5		dBm	

Note: Stress in excess of the maximum absolute ratings can cause permanent damage to the transceiver.

Recommended Operating Conditions

Parameter	Symbol	Min.	Typ	Max.	Unit	Note
Data Rate	DR		103.2	112	Gb/s	
Supply Voltage	Vcc	3.14	3.3	3.46	V	
Operating Case Temp.	Tc	0		70	°C	

Electrical Characteristics (Top=0~70°C, Vcc=3.2~3.4V)

(Tested under recommended operating conditions, unless otherwise noted)

Parameter	Symbol	Min	Typ	Max	Unit	Notes
Supply Current	I _{cc}			5	A	
Supply Voltage	V _{cc}	3.2		3.4	V	
Transmitter						
Signaling rate per lane	DR _{PL}			11.2	Gb/s	
Input differential impedance	R _{in}		100		Ω	
Differential data input swing per lane	V _{in,pp}			760	mV	
Data input rise time tolerance	T _r	24			Ps	1
Data input fall time tolerance	T _f	24			ps	1
Electrical input eye mask definition	{X1,X2} {Y1,Y2}		{0.2,0.5} {136,380}		UI mV	
Power Supply Noise Tolerance	V _{rip}	Per CFP MSA Specification				
Receiver						
Signaling rate per lane	DR _{PL}			11.2	Gb/s	
Differential data output swing per lane	V _{out,pp}			760	mV	
Data output rise time tolerance	T _r	24	80		ps	1
Data output fall time tolerance	T _f	24	80		ps	1
Electrical input eye mask definition	{X1,X2} {Y1,Y2}		{0.2,0.5} {136,380}		UI mV	
Power Supply Noise Tolerance	V _{rip}	Per CFP MSA Specification				

Notes:

1.20%~80%

Optical Characteristics (Top=0~70°C, Vcc=3.2~3.4V)

(Tested under recommended operating conditions, unless otherwise noted)

Parameter	Symbol	Unit	Min	Typ	Max	Notes
Transmitter						
Signaling rate, each lane		GBd	25.78125 ±100 ppm			100GBase-LR4,1
			27.9525 ±20 ppm			OTU4,1
Four Lane Wavelength Range	λ1	nm	1294.53	1295.56	1296.59	
	λ2		1299.02	1300.05	1301.09	
	λ3		1303.54	1304.58	1305.63	
	λ4		1308.09	1309.14	1310.19	
Total launch power	Pout	dBm			10.5	100GBase-ER4
					10	OTU4
Average launch power, each lane	Pavg	dBm	-2.9		2.9	100GBase-ER4,2
			-6		4	OTU4,2
Optical modulation amplitude, each lane (OMA) ²	OMA	dBm	-1.3		4.5	
Difference in launch power between any two lanes (OMA)		dB			5	
Extinction ratio	ER	dB	4			100GBase-ER4
			4		6.5	OTU4
Side-mode suppression ratio	SMSR	dB	30			
Transmitter and dispersion penalty, each lane	TDP	dB			2.2	
Optical return loss tolerance		dB			20	
Transmitter reflectance ³		dB			-12	
Transmitter eye mask {X1, X2, X3, Y1, Y2, Y3}			{0.25, 0.4, 0.45, 0.25, 0.28, 0.4}			100GBase-ER4
Optical Receiver Characteristics						
Receive Rate for Each Lane		Gbps		25.78125	27.9525	3
Overload Input Optical Power	Pmax	dBm	5.5			

Average Receive Power for Each Lane	Pin	dBm	-20.9		4.5	4
Receiver Sensitivity(OMA)per lane	Psens1	dBm			-17.9	
Stressed Sensitivity(OMA) per lane	Psens2	dBm			-15.9	
Return Loss	RL	dB	-26			
Receiver Electrical 3dB upper cutoff frequency, per lane		GHz			31	
Los De-Assert	Pd	dBm			-19	
Los Assert	Pa	dBm			-21	
Loss Hysteresis	Pd-Pa	dBm	1			

Notes:

1. Transmitter consists of 4 lasers operating at 25.78Gb/s each for 100GBASE-LR, 27.95Gb/s each for OTU4
2. Minimum value is informative.
3. Receiver consists of 4 photodetectors operating at 25.78Gb/s each each for 100GBASE-LR, 27.95Gb/s each for OTU4
4. Minimum value is informative, equals min TxOMA with infinite ER and max channel insertion loss.

Pin Description

	Top View		Bottom View
148	GND	1	3.3V_GND
147	REFCLKn	2	3.3V_GND
146	REFCLKp	3	3.3V_GND
145	GND	4	3.3V_GND
144	N.C.	5	3.3V_GND
143	N.C.	6	3.3V
142	GND	7	3.3V
141	TX9n	8	3.3V
140	TX9p	9	3.3V
139	GND	10	3.3V
138	TX8n	11	3.3V
137	TX8p	12	3.3V
136	GND	13	3.3V
135	TX7n	14	3.3V
134	TX7p	15	3.3V
133	GND	16	3.3V_GND
132	TX6n	17	3.3V_GND
131	TX6p	18	3.3V_GND
130	GND	19	3.3V_GND
129	TX5n	20	3.3V_GND
128	TX5p	21	VND_IO_A
127	GND	22	VND_IO_B
126	TX4n	23	GND
125	TX4p	24	TX_MCLKn
124	GND	25	TX_MCLKp
123	TX3n	26	GND
122	TX3p	27	VND_IO_C
121	GND	28	VND_IO_D
120	TX2n	29	VND_IO_E
119	TX2p	30	PRG_CNTL1
118	GND	31	PRG_CNTL2
117	TX1n	32	PRG_CNTL3
116	TX1p	33	PRG_ALARM1
115	GND	34	PRG_ALARM2
114	TX0n	35	PRG_ALARM3
113	TX0p	36	TX_DIS
112	GND	37	MOD_LOPWR

	Top View		Bottom View
111	GND	38	MOD_ABS
110	N.C.	39	MOD_RSTn
109	N.C.	40	RX_LOS
108	GND	41	GLB_ALRMn
107	RX9n	42	PRTADR4
106	RX9p	43	PRTADR3
105	GND	44	PRTADR2
104	RX8n	45	PRTADR1
103	RX8p	46	PRTADR0
102	GND	47	MDIO
101	RX7n	48	MDC
100	RX7p	49	GND
99	GND	50	VND_IO_F
98	RX6n	51	VND_IO_G
97	RX6p	52	GND
96	GND	53	VND_IO_H
95	RX5n	54	VND_IO_J
94	RX5p	55	3.3V_GND
93	GND	56	3.3V_GND
92	RX4n	57	3.3V_GND
91	RX4p	58	3.3V_GND
90	GND	59	3.3V_GND
89	RX3n	60	3.3V
88	RX3p	61	3.3V
87	GND	62	3.3V
86	RX2n	63	3.3V
85	RX2p	64	3.3V
84	GND	65	3.3V
83	RX1n	66	3.3V
82	RX1p	67	3.3V
81	GND	68	3.3V
80	RX0n	69	3.3V
79	RX0p	70	3.3V_GND
78	GND	71	3.3V_GND
77	RX_MCLKn	72	3.3V_GND
76	RX_MCLKp	73	3.3V_GND
75	GND	74	3.3V_GND

Pin	Name	I/O	Logic	Description
1	3.3V_GND			3.3V Module Supply Voltage Return Ground, internally connected to Signal Ground
2	3.3V_GND			3.3V Module Supply Voltage Return Ground, internally connected to Signal Ground
3	3.3V_GND			3.3V Module Supply Voltage Return Ground, internally connected to Signal Ground
4	3.3V_GND			3.3V Module Supply Voltage Return Ground, internally connected to Signal Ground
5	3.3V_GND			3.3V Module Supply Voltage Return Ground, internally connected to Signal Ground
6	3.3V			3.3V Module Supply Voltage
7	3.3V			3.3V Module Supply Voltage
8	3.3V			3.3V Module Supply Voltage
9	3.3V			3.3V Module Supply Voltage
10	3.3V			3.3V Module Supply Voltage
11	3.3V			3.3V Module Supply Voltage
12	3.3V			3.3V Module Supply Voltage
13	3.3V			3.3V Module Supply Voltage
14	3.3V			3.3V Module Supply Voltage
15	3.3V			3.3V Module Supply Voltage
16	3.3V_GND			3.3V Module Supply Voltage Return Ground, internally connected to Signal Ground
17	3.3V_GND			3.3V Module Supply Voltage Return Ground, internally connected to Signal Ground
18	3.3V_GND			3.3V Module Supply Voltage Return Ground, internally connected to Signal Ground
19	3.3V_GND			3.3V Module Supply Voltage Return Ground, internally connected to Signal Ground
20	3.3V_GND			3.3V Module Supply Voltage Return Ground, internally connected to Signal Ground
21	VND_IO_A	I/O		Module Vendor I/O A. Do Not Connect!
22	VND_IO_B	I/O		Module Vendor I/O B. Do Not Connect!
23	GND			
24	TX_MCLKn	O		Freq = Optical rate/32. Utilized for optical waveform testing. Not for normal use.
25	TX_MCLKp	O		Freq = Optical rate/32. Utilized for optical waveform testing. Not for normal use.
26	GND			
27	VND_IO_C	I/O		Module Vendor I/O C. Do Not Connect!

28	VND_IO_D	I/O		Module Vendor I/O D Do Not Connect!
29	VND_IO_E	I/O		Module Vendor I/O E. Do Not Connect!
30	PRG_CNTL1	I	LVC MOS w/PUR	Programmable Control 1 set over MDIO, Default: TRXIC_RSTn, TX & RX ICs reset, "0": reset; "1" or NC: enabled (i.e., not used).
31	PRG_CNTL2	I	LVC MOS w/PUR	Programmable Control 2 set over MDIO, Default: Hardware Interlock LSB, "00": ≤8W; "01": ≤16W; "10": ≤24W; "11" or NC: ≤32W (i.e., not used).
32	PRG_CNTL3	I	LVC MOS w/PUR	Programmable Control 3 set over MDIO, Default: Hardware Interlock LSB, "00": ≤8W; "01": ≤16W; "10": ≤24W; "11" or NC: ≤32W (i.e., not used).
33	PRG_ALRM1	O	LVC MOS	Programmable Alarm 1 set over MDIO, Default: HIPWR_ON, "1": module power up completed; "0": module not high powered up.
34	PRG_ALRM2	O	LVC MOS	Programmable Alarm 2 set over MDIO, Default: MOD_READY, "1": Ready; "0": not Ready.
35	PRG_ALRM3	O	LVC MOS	Programmable Alarm 3 set over MDIO, Default: MOD_FAULT, fault detected, "1": Fault; "0": No Fault.
36	TX_DIS	I	LVC MOS w/PUR	Transmitter Disable for all lanes, "1" or NC = transmitter disabled, "0" = transmitter enabled
37	MOD_LOPW	I	LVC MOS w/PUR	Module Low Power Mode. "1" or NC: module in low power (safe) mode, "0": power-on enabled
38	MOD_ABS	O	GND	Module Absent. "1" or NC: module absent, "0": module present, Pull Up Resistor on Host
39	MOD_RSTn	I	LVC MOS w/PDR	Module Reset. "0" resets the module, "1" or NC = module enabled, Pull Down Resistor in Module
40	RX_LOS	O	LVC MOS	Receiver Loss of Optical Signal, "1": low optical signal, "0": normal condition
41	GLB_ALRMn	O	LVC MOS	Global Alarm. "0": alarm condition in any MDIO Alarm register, "1": no alarm condition, Open Drain, Pull Up Resistor on Host
42	PRTADR4	I	1.2V CMOS	MDIO Physical Port address bit 4
43	PRTADR3	I	1.2V CMOS	MDIO Physical Port address bit 3
44	PRTADR2	I	1.2V CMOS	MDIO Physical Port address bit 2
45	PRTADR1	I	1.2V CMOS	MDIO Physical Port address bit 1
46	PRTADR0	I	1.2V CMOS	MDIO Physical Port address bit 0
47	MDIO	I/O	1.2V CMOS	Management Data I/O bi-directional data (electrical specs as per 802.3ae and ba)
48	MDC	I	1.2V CMOS	Management Data Clock (electrical specs as per 802.3ae and ba)
49	GND			
50	VND_IO_F	I/O		Module Vendor I/O F. Do Not Connect!
51	VND_IO_G	I/O		Module Vendor I/O G. Do Not Connect!
52	GND			
53	VND_IO_H	I/O		Module Vendor I/O H. Do Not Connect!
54	VND_IO_J	I/O		Module Vendor I/O J. Do Not Connect!

55	3.3V_GND			3.3V Module Supply Voltage Return Ground, internally connected to Signal Ground
56	3.3V_GND			3.3V Module Supply Voltage Return Ground, internally connected to Signal Ground
57	3.3V_GND			3.3V Module Supply Voltage Return Ground, internally connected to Signal Ground
58	3.3V_GND			3.3V Module Supply Voltage Return Ground, internally connected to Signal Ground
59	3.3V_GND			3.3V Module Supply Voltage Return Ground, internally connected to Signal Ground
60	3.3V			3.3V Module Supply Voltage
61	3.3V			3.3V Module Supply Voltage
62	3.3V			3.3V Module Supply Voltage
63	3.3V			3.3V Module Supply Voltage
64	3.3V			3.3V Module Supply Voltage
65	3.3V			3.3V Module Supply Voltage
66	3.3V			3.3V Module Supply Voltage
67	3.3V			3.3V Module Supply Voltage
68	3.3V			3.3V Module Supply Voltage
69	3.3V			3.3V Module Supply Voltage
70	3.3V_GND			3.3V Module Supply Voltage Return Ground, internally connected to Signal Ground
71	3.3V_GND			3.3V Module Supply Voltage Return Ground, internally connected to Signal Ground
72	3.3V_GND			3.3V Module Supply Voltage Return Ground, internally connected to Signal Ground
73	3.3V_GND			3.3V Module Supply Voltage Return Ground, internally connected to Signal Ground
74	3.3V_GND			3.3V Module Supply Voltage Return Ground, internally connected to Signal Ground
75	GND			
76	RX_MCLKp			For optical waveform testing. Not for normal use.
77	RX_MCLKn			For optical waveform testing. Not for normal use.
78	GND			
79	RX0p			SFI-5.0 interface
80	RX0n			SFI-5.0 interface
81	GND			

82	RX1p			SFI-5.0 interface
83	RX1n			SFI-5.0 interface
84	GND			
85	RX2p			SFI-5.0 interface
86	RX2n			SFI-5.0 interface
87	GND			
88	RX3p			SFI-5.0 interface
89	RX3n			SFI-5.0 interface
90	GND			
91	RX4p			SFI-5.0 interface
92	RX4n			SFI-5.0 interface
93	GND			
94	RX5p			SFI-5.0 interface
95	RX5n			SFI-5.0 interface
96	GND			
97	RX6p			SFI-5.0 interface
98	RX6n			SFI-5.0 interface
99	GND			
100	RX7p			SFI-5.0 interface
101	RX7n			SFI-5.0 interface
102	GND			
103	RX8p			SFI-5.0 interface
104	RX8n			SFI-5.0 interface
105	GND			
106	RX9p			SFI-5.0 interface
107	RX9n			SFI-5.0 interface
108	GND			
109	N.C.			
110	N.C.			

111	GND			
112	GND			
113	TX0p			SFI-5.0 interface
114	TX0n			SFI-5.0 interface
115	GND			
116	TX1p			SFI-5.0 interface
117	TX1n			SFI-5.0 interface
118	GND			
119	TX2p			SFI-5.0 interface
120	TX2n			SFI-5.0 interface
121	GND			
122	TX3p			SFI-5.0 interface
123	TX3n			SFI-5.0 interface
124	GND			
125	TX4p			SFI-5.0 interface
126	TX4n			SFI-5.0 interface
127	GND			
128	TX5p			SFI-5.0 interface
129	TX5n			SFI-5.0 interface
130	GND			
131	TX6p			SFI-5.0 interface
132	TX6n			SFI-5.0 interface
133	GND			
134	TX7p			SFI-5.0 interface
135	TX7n			SFI-5.0 interface
136	GND			
137	TX8p			SFI-5.0 interface
138	TX8n			SFI-5.0 interface
139	GND			

140	TX9p			SFI-5.0 interface
141	TX9n			SFI-5.0 interface
142	GND			
143	N.C.			
144	N.C.			
145	GND			
146	REFCLKp			SFI-5.0 interface
147	REFCLKn			SFI-5.0 interface
148	GND			

Notes:

1. Pin#75~148 belong to High Speed Electrical Pin, No Descriptions.

Package Dimensions

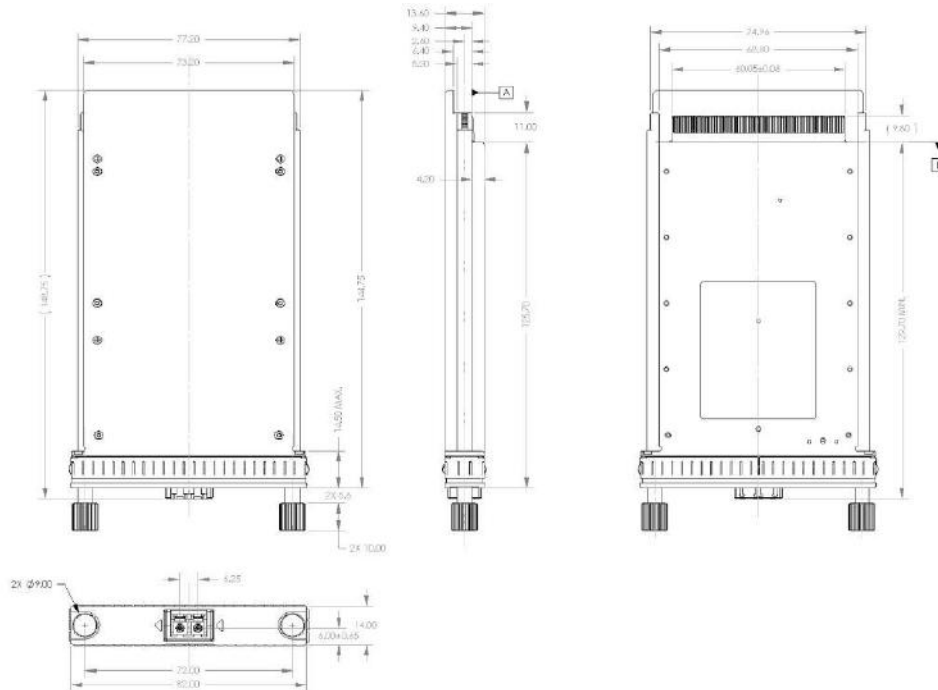



<https://www.lanaotek.com>



Specifications & design are subject to change without prior notice.
For more details, please email to info@lanaotek.com. Copyright©2024 lanaotek.com All Rights Reserved