

LA-SBV20-SW

Ethernet Smart Box - Intelligent Communication and Protection Cabinet

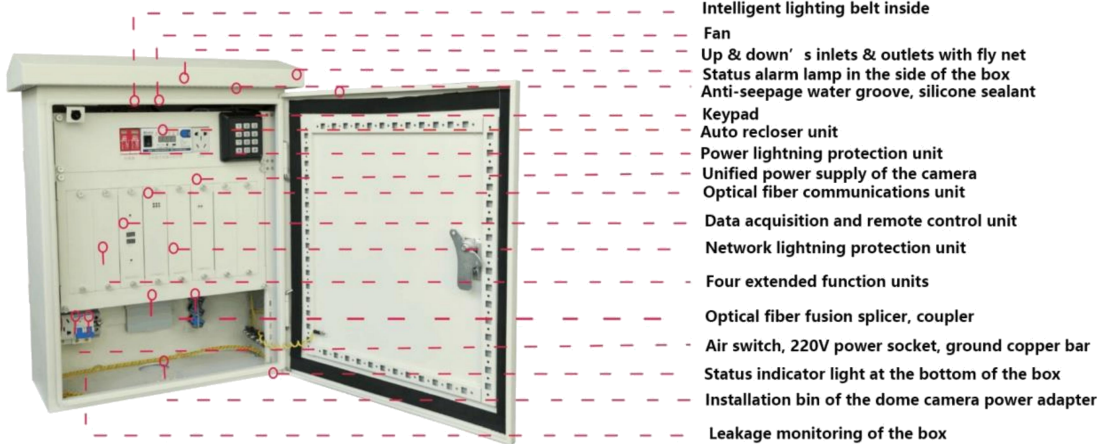

Introduction

Intelligent monitoring and protection cabinet products are according to the smart city, safe city, intelligent transportation and other areas of video information management, Reaching and developing the cabinet communication device. This product meet the original protection communication box various requirements, Combined with the characteristics of safe city information management, added the application of Internet communication technology, adopt modular layout. The perfect network management and the work condition display, ensure the entire system the reliability, the continuity and the intelligence, is a excellent product in security industry.

Features

● Highly Integrated

This cabinet integrating chassis, front-end information acquisition and remote control, series sensors, power modules, lighting protection, optical fiber communication modular, automatic reclosure and power control, it has compact, reasonable layout and beautiful appearance.

● Modular Design

All functional units inside the box are modular design, while maintaining the versatility of the box, a variety of configurations are provided to suit the different application scenarios, at the same time, it is easy to extend, maintain and maximize the life cycle of infrastructure, so as to realize the maintenance and increment of infrastructure.

● Flexible Deployment and Convenient Maintenance

All functional units are factory preset, just need to connect the optical fiber, the network, the data and the power line with the preset interface of the box when using it, do not need to disassemble the box board and module could complete the deployment.

- **Can be Run Independently**

Hardware device can display the data of local temperature, humidity, current and voltage, it can complete all parameter settings without software, and will save the collected data, the data will not be lost when the network is disconnected or disconnected.

- **Centralized Power Supply**

Provides 1-3 220V power output ports, 5 DC12V power output, it can be used to camera and sensors power supply. The output of DC12V power supply has over-current, over voltage and short circuit protection function.

- **Automatic Reclosing Devices**

With over-current short-circuit protection, under-voltage/over-voltage protection, leakage protection, fault memories, before closing detection, automatic overlap intelligent control function.

- Short-Circuit Protection

When the automatic reclosing leakage protector current more than 3 times the rated current, the protectors will be disconnect in 0.1 seconds to assure the safety of the equipment.

- Leakage Protection

Leakage start current is 30mA, the leakage current between the 15~ 30mA, the automatic reclosing leakage protector will be disconnect 30m in 0.1 seconds.

- Over-current/Over-load Protection

The rated current can be adjusted 6A-10A-16A, maximum support 16A. The current mote than 1.15 times rated current and the duration longer than 3 seconds or more than 3 times rated current, the automatic reclosing leakage protector will be disconnect to protection the equipment.

- Over-voltage Protection

When the supply voltage higher than $208V \pm 5V$ (It can be adjusted according the requirements), automatic reclosing device disconnect. Once the voltage is restored to normal, the device will be automatic reclosing power.

- Under-voltage protection

When the supply voltage lower than $150 \pm 5V$ (it can be adjusted according the requirements), The voltage is restored to normal, the automatic reclosing device automatic closing, power is running properly.

- Closing Detection

Automatic reclosing device detect the voltage before the closing, when the supply voltage is abnormal under voltage and over voltage, the device closing and alarm.

- Automatic Reclosing Device

The instantaneous leakage or instantaneous impact happened (such as thunder, Socket jump fire, etc) it could be dangerous, the device will be disconnected in time; After the fault, the line is safe, automatic reclosing leakage protector will connect automatically. The number of closing times is unlimited.

- Manual On-off Performance

Manually press the test button leakage, N wire and L wire disconnect, no output, after 60 seconds the automatic closing, automatic reclosing to normal working state; manually turn off the power switch, and the N wire is disconnected from the L wire at the same time, without output. The On-off action time is less than 0.1 seconds. Restart the switch power supply, N wire and L wire output with the same time.

- **Data Acquisition and Remote Control**

- Box Status Detection Function

1. The temperature and humidity detection: the local real-time display of temperature and humidity, temperature and humidity and upload box, according to the temperature and humidity set limit on the fan start and stop control. At the same time, the local alarm is too high.

2. The box door state detection: the real-time detection of the box door, the box door opened illegally alarm, open the door after the way through the center of the authorization or enter a password to achieve delay alarm. When the door opened illegally, and external linkage positioning ball machine and open the strobe light photographing.

3. The box is light intensity detection: real-time detection in illumination, realize the lighting intelligent open.

4. The box is water leakage monitoring: collection and upload the water leakage situation.

- The Detection Function of the Box Equipment
 1. The fan running state detection: can remotely view the running state of fan.
 2. The lightning arrester state detection: real-time detection of lightning protection device health state, recorded and uploaded by the number of lightning and lightning box size.
 3. The 220V power detection: real-time monitoring and upload voltage, current state, leakage current.
 4. The circuit breaker status detection: real-time detection of circuit breaker closing state, trip times, trip type (reason).

- Remote Control Function
 1. To adjust brightness of lights: according to actual situation of remote and local brightness adjusting pole lights.
 2. The fan control: remote control fan start and stop.
 3. The lighting lamp control: remote control lamp switch.
 4. The strobe control: up to 2 remote control strobe open road.
 5. The circuit breaker control: remote power-off restart.

- 2.4 Optical Fiber Communication

Optical Fiber Communication unit is a 10/100/1000M fast auto-negotiation Fiber Ethernet Switch, which support 1/2 1000Base-FX and 4/5 10/100/1000Base-T(X). This unit meet the Ethernet standard, add the lightning protection, together with the anti-static components, to ensure its Reliability and stability.

 1. Support TCP/IP, PPPOE, DHCP, ICMP, NAT agreement.
 2. Full duplex adopt IEEE 802.3X standard and the half duplex adopt Backpressure standard.
 3. Ethernet port is auto-negotiation, auto speed and transmission control.
 4. Support Auto-MDI/MDIX auto detect.
 5. Support Store and Forward .
 6. Support 10M, 100M, 1000M or auto-negotiation.
 7. Support status indicator, external power (Output: 5V~ 50HZ / 1A).
 8. Modular power design, separate design of function board & power supply, convenient for future maintenance.
 9. Adopt the unique integrated circuit solution design, lower chip temperature, get rid of the heat dissipation system, realize flow control.
 10. High quality photoelectric integrated module design, with its superior optical properties and electrical properties, can guarantee the reliable transmission, long service life.
 11. Broadcast filtering function, address automatic learning and automatic update function and storage and forwarding mechanism.
 12. Support maximum 1916byte transmission.
 13. Support for remote link loss and diagnostics, copper port link & fiber port link diagnostics, dynamic data transmission, full duplex/half duplex, rate indicator, easy installation and maintenance.
 14. Low power consumption, less than 2.5W, low fever, ensure long time stable work.

- Lightning Protection

This box has the function of AC power 220V lightning protection and the network surge arrester. It can protect the AC 220V strong current and the 4 ports network lightning protection.

- Powerful Protection Capability

AC power 220V lightning protection modules' surge release capability can up to 40KA(8/20us) discharge current; Network surge arrester Up: Line-earth: 600V; Line-Line: 25V. It can pass the complex wave test of C2: 5kV/2.5KA.

- The Feature of AC 220V Lightning Protection Unit

Built-in over current circuit breaker, remote alarm interface, failure detection indication, overheat circuit breaker, standard modular installation.

- Extended Functionality

You can extend the following functions by reserving 4 functional extension units:

 1. DC (AC) power distribution unit with monitoring and control function;
 2. Eight optical fiber communication modules;
 3. 3G/4G transmission communication;
 4. GPS location;
 5. Audio transmission; 6. Smoke detection, alarm and other functions.

Configuration List

Product Name	Model	Description
Operation and maintenance management software	LA-SBV20-OMS	Cloud platform integrated management platform, consisting of personal computer and application operation and maintenance
Seiko chassis	LA-SBV20-Box01	1.2mm thickness Seiko chassis Dimension: 430*220*530mm
Data Management	LA-SBV20-Data-01	Realize status control, switch control, remote management functions
Networking lightning protection (8 ports)	LA-SBV20-8SPD-1000	8*10/100/1000M compatible network lightning protection
Managed PoE switch	LA-SBV20-7PoE-10	L2+ managed PoE switch with 7*10/100/1000Base-T PoE ports and 2*100/1000Base-X SFP fiber ports
AC24V power supply	LA-SBV20-PWR-AC24	1 set of AC24V / 2.5A, 60W AC power supply
DC48V power supply	LA-SBV20-PWR-DC48	1 set of DC48V / 5A, 240W DC power supply
Auto-reclosing	LA-SBV20-175275-16A	Working voltage: 175-275VAC 50-60Hz, 16A
AC power supply lightning arrester	LA-SBV20-SPD-220AC	1 set of power lightning arrester: 220V max: 20kA, In: 10KA
Optical fiber terminal box and power adapter	LA-SBV20-ODF4	Optical fiber terminal box and and power adapter
LED lighting	LA-SBV20-LED	LED lighting inside the case

Specifications

PART NO	LA-SBV20-SW
Power Configuration	
220V AC power supply air switch	1 set, 220V/20A
AC power supply lightning arrester	1 set of power lightning arrester: 220V max: 20kA, In: 10KA Voltage protection Level 1.1kV Adding 1.2/50us (8-20us) combined wave of L-N, 2KV does not cause to malfunction, 6KV is non-damaged, the upper limit is 10KV
Auto-reclosing	Working voltage 175-275VAC 50-60Hz Rated output current 10A Electric leakage protection / action time 300mA/ 0.1S Over voltage protection / action time AC275V/2-5S Under voltage protection / action time AC145V/2-5S Over current protection / action time 16A/2-5S Short circuit protection/ action time 3 times input current/ 0.1S Detection function before closing, with remote control function
AC24V power supply	1 set of AC100-264V input, AC24V/2.5A output, 60W AC power supply
DC48V power supply	1 set of DC48V / 5A, 240W DC power supply
Power Consumption	Standby< 50W, Full Load< 1500W
Data Control Unit	
Data port	1ch RS232 data 2ch switch interface 3ch RS485 data
Extended function port	1ch automatic heating control 1ch lighting control 1ch fan control 1ch leak detection control 1ch local storage SD card slot, 1ch 4th generation mobile communication technology wireless routing expansion slot
Alarm output port	1ch alarm output 1ch status indicator output 1ch door status output 1ch automatic lighting status output
Controlled power supply	3ch 12VDC outputs, 1ch 24VAC output
Ethernet port	1*10/100Base-TX RJ45 port for transmitting control signals
Screen display	A status display LCD screen, used to display the address of the device, query the status of various control switches
Tamper alarm	Unpacking alarm signal output

PoE Power Supply Transmission	
Fixed port	8*10/100/1000Base-T PoE ports (Data/Power) 2*100/1000Base-X SFP fiber slot ports (Data) 1*Console RS232 port (115200,N,8,1)
Ethernet port	Port 1-8 can support 10/100/1000Base-T auto-sensing,Full/half duplex MDI/MDI-X self-adaption
Twisted pair transmission	10BASE-T: Cat3,4,5 UTP(100 meter) 100BASE-TX: Cat5 or later UTP(100 meter) 1000BASE-T: Cat5e or later UTP(100 meter)
Optical fiber port	Gigabit SFP optical fiber port, default matching optical modules (optional order single-mode / multi-mode, single fiber / dual fiber optical module. LC)
Optical Cable	Multi-mode: 850nm/ 0~ 500m, Single-mode: 1310nm 0~ 40km,1550nm
Distance	0~ 120km
Chip Parameter	
Network management type	L2+
Network protocol	IEEE802.3 10BASE-T, IEEE802.3i 10Base-T IEEE802.3u 100Base-TX, IEEE802.3ab 1000Base-T IEEE802.3z 1000Base-X IEEE802.3x
Forwarding mode	Store and Forward(Full Wire Speed)
Switching capacity	192Gbps (non-blocking)
Forwarding rate@ 64byte	14.88Mpps
MAC	8K
Buffer memory	4M
Jumbo frame	9.6K
LED Indicator	Power: PWR (green), system:SYS (yellow); network:Link (yellow); PoE: PoE (green); Fiber port : L/A (green)
Reset switch	Yes, support one key to restore factory settings
PoE & Power	
PoE port	Port 1 to 7
PoE management	PoE working status Delay start of power supply PoE output priority configuration Scheduling of PoE operation and time Total power limit of PoE power supply PoE output power allocation, off& af &at

Power supply pin	Default: 1/2 (+), 3/6 (-)
Max power per port	30W, IEEE802.3af/at
Total PWR / input voltage	240W/48VDC
Power Consumption	Standby< 8W, Full Load< 240W
Network Management Features	
Interface	IEEE802.3X (Full-duplex) Port temperature protection setting Port green Ethernet Energy-saving setting Broadcast storm control based on port speed The speed limit of the message flow in the access port The minimum particle size is 64Kbps
Layer 3 features	L2+ network management ,IPV4/IPV6 management L3 soft routing forwarding, Static route, Default route @ 128 pcs, APR @ 1024 pcs
VLAN	4K VLAN based on port, IEEE802.1q VLAN based on the protocol VLAN based on MAC Voice VLAN, QinQ configuration Port configuration of Access, Trunk, Hybrid
Port aggregation	LACP, Static aggregation Max 5 aggregation groups and 8 ports per group
Spanning tree	STP (IEEE802.1d),RSTP (IEEE802.1w),MSTP (IEEE802.1s)
Industrial ring	G.8032 (ERPS),Recovery time less than 20ms
Network protocol	255 Ring at most, Max 1024 devices per ring
Multicast	MLD Snooping v1/v2,Multicast VLAN IGMP Snooping v1/v2, Max 1024 multicast groups, Fast log out
Port mirroring	Bidirectional data mirroring based on port
QoS	Flow-based Rate Limiting Flow-based Packet Filtering 8* Output queues of each port 802.1p/DSCP priority mapping Diff-Serv QoS,Priority Mark/Remark Queue Scheduling Algorithm (SP, WRR, SP+ WRR)
ACL	Port-based Issuing ACL,ACL based on port and VLAN L2 to L4 packet filtering, matching first 80 bytes message. Provide ACL based on MAC, Destination MAC address, IP Source, Destination IP, IP Protocol Type, TCP/UDP Port, TCP/UDP Port Range, and VLAN, etc
Security	IP-MAC-VLAN-Port binding ARP inspection,Anti-DoS attack AAA & RADIUS,MAC learning limit Mac black holes,IP source protection IEEE802.1X & MAC address authentication Broadcast storm control,Backup for host datum SSH 2.0,SSL,Port isolation,ARP message speed limit User hierarchical management and password protection

DHCP management	DHCP Client,DHCP Snooping, DHCP Server,DHCP Relay One-key recovery Cable Diagnose,LLDP Web Management (HTTPS) NTP,System work log,Ping Test CPU instant utilization status view Console/AUX Modem/Telnet/SSH2.0 CLI Download & Management on FTP, TFTP, Xmodem, SFTP,SNMP V1/V2C/V3 LA OMS - smart network management system platform(LLDP+SNMP)
Physical Parameter	
Operation TEMP / humidity	-20~ + 70° C; 5% ~ 90% RH Non condensing
Storage TEMP / humidity	-40~ + 75° C; 5% ~ 95% RH Non condensing
MTBF	> 100,000 hours
Dimension (L*W*H)	541* 440* 240mm
Net /Gross weight	< 17kg / < 20kg
Installation	pole hoop mount
Certification & Warranty	
Lightning protection / protection level	Lightning protection: 6KV 8/20us; Protection level: IP55
Certification	CCC;CE mark, commercial; CE/LVD EN60950;FCC Part 15 Class B;RoHS
Warranty	3 years, lifelong maintenance

Dimension

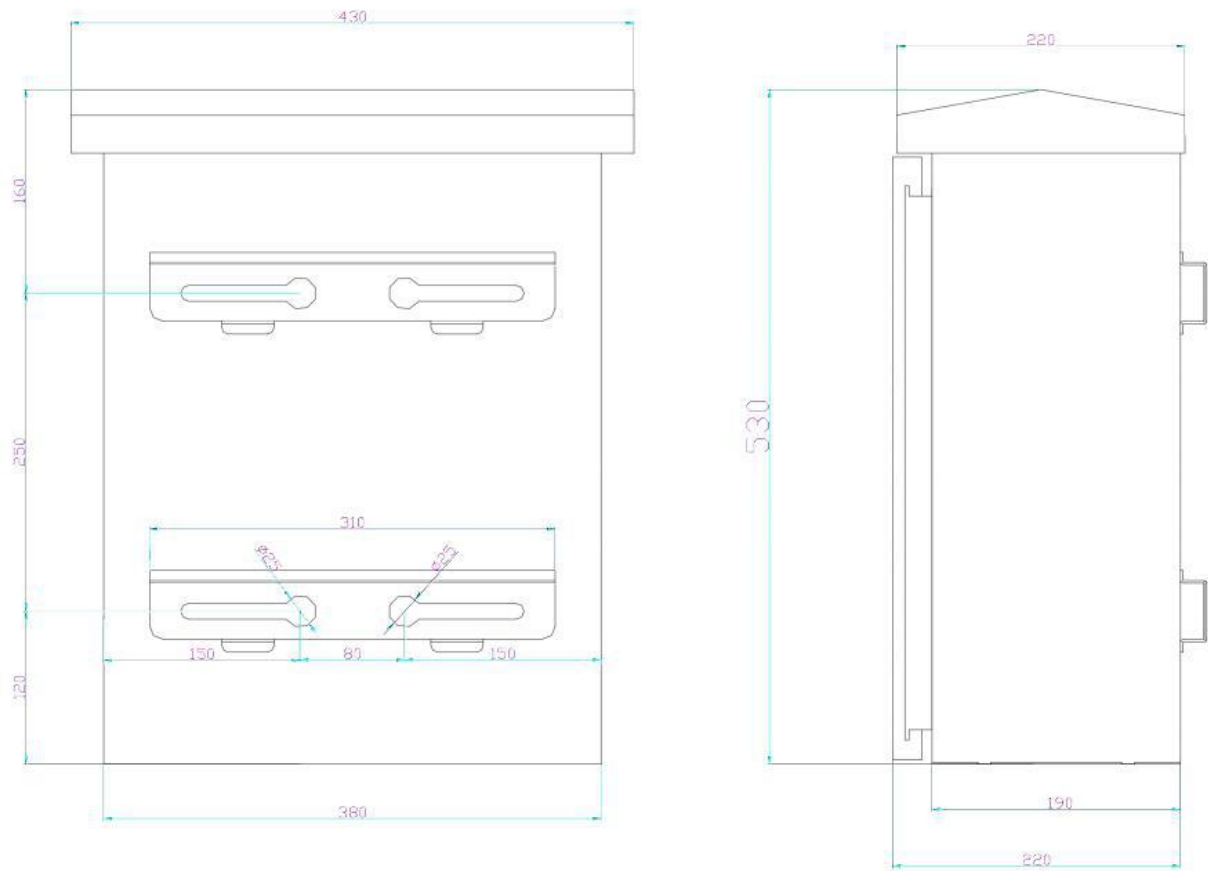

Installation Steps

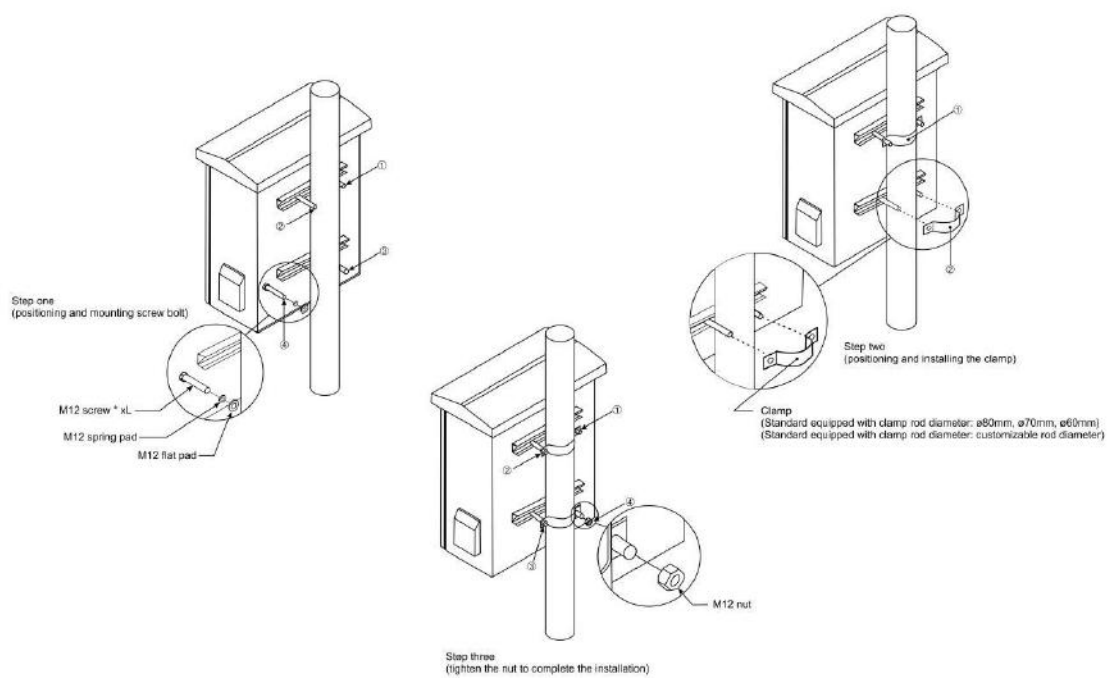

Applications

- Safe city security surveillance system
- Intelligent traffic security system
- Oil, mining, power security system
- Smart cell security

Ordering Information

Part No	Description
LA-SBV20-PoE	PoE intelligent control box with lightning arrester, air switch, power automatic closing protection module, multi-output power module, Ethernet switch, optical fiber terminal box, etc. It has 8* 10/100/1000M RJ45 ports and 2* 100/1000M SFP slot ports. Port 1-8 can support IEEE802.3af/at standard PoE. remotely control through a cloud platform, realize cluster management, pole hoop mounting.
LA-SBV20-SW	Ethernet intelligent control box with lightning arrester, air switch, power automatic closing protection module, multi-output power module, Ethernet switch, optical fiber terminal box, etc. It has 8* 10/100/1000M RJ45 ports and 2* 100/1000M SFP slot ports. remotely control through a cloud platform, realize cluster management, pole hoop mounting.
LA-SBV20-AC/DC	Intelligent control box with lightning arrester, air switch, power automatic closing protection module, multi-output power module, etc. It can be used with other control boxes, remotely control through a cloud platform, realize cluster management, pole hoop mounting.
LA-SBV20-NDR-240	NDR control box with MW 240W power supply, lightning arrester, air switch, power automatic closing protection module, multi-output power module, etc. It can be used with other control boxes, remotely control through a cloud platform, realize cluster management, pole hoop mounting.