

LA-IS4N-G0008

8*10/100/1000 Base-T Unmanaged Industrial Switch (PoE Optional)

Highlight Information ▶▶▶▶

LA-XXX/LAM-XXX Series

For LA-XXX Series

For LA-XXX Series



Introduction

This device 8*10/100/1000Base-T Industrial Ethernet Switch, PoE is optional. Through the fanless heat dissipation circuit design, wide range of working environment temperature $-30^{\circ}\text{C}\sim 75^{\circ}\text{C}$, high protection level and other technologies, it provides excellent industrial quality with high/low temperature resistance and lightning protection, and enhances the reliability and safety of industrial networks.

The device can be widely applied to various broadband data transmission fields such as intelligent transportation, telecommunications, security, financial securities, customs, shipping, power, water conservancy and oil fields.

Features

- **Input Voltage:** DC12~58V(Non-PoE)/DC48~58V(PoE)
- **Shell:** IP40 protection, fanless design
- **Anti-static:** 8KV-15KV
- **Operating Temperature:** $-30^{\circ}\text{C} \sim +75^{\circ}\text{C}$
- **Test Report:** CCC, RoHS, FCC, CE
- **MTBF:** 100000 Hours

Specification

PART NO	LA-IS4N-G0008
Provider Mode Ports	
Fixed Port	8*10/100/1000Base-T
Power Interface	Phoenix terminal, dual power supply
LED Indicators	PWR, Link/ACT LED
Cable Type & Transmission Distance	
Twisted-pair	0-100m (CAT5e,CAT6)
Monomode Optical Fiber	/
Multimode Optical Fiber	/
Network Topology	
Ring Topology	Unsupported
Star Topology	Support
Bus Topology	Support
Tree Topology	Support
Electrical Specifications	
Input Voltage	DC12-58V(Non-PoE)/DC48~58V(PoE)
Total Power Consumption	Non PoE<5W, with PoE<125W
Layer 2 Switching	
Switching Capacity	20G
Packet Forwarding Rate	14.88Mpps
MAC Address Table	16K
Buffer	2M
Forwarding Delay	<5us
MDX/MIDX	Support
Flow Control	Support
Jumbo Frame	10bytes
Environment	
Operating Temperature	-30℃~75℃
Storage Temperature	-30℃~75℃
Relative Humidity	5%~90% (non-condensing)
Thermal Methods	Fanless, natural cooling
MTBF	100,000 hours
Mechanical Dimensions	
Product Size	143*104*46mm (W×H×D)
Installation Method	DIN-rail
Weight	0.54KG around

EMC & Ingress Protection	
IP Level	IP40
Surge Protection of Power	IEC 61000-4-5 Level 3 (4KV/2KV) (8/20us)
Surge Protection of Ethernet Port	IEC 61000-4-5 Level 3 (4KV/2KV) (10/700us)
ESD	IEC 61000-4-2 Level 4 (8K/15K)
Authentication	
Authentication	CCC/CE/FCC/RoHS

■ Dimensions

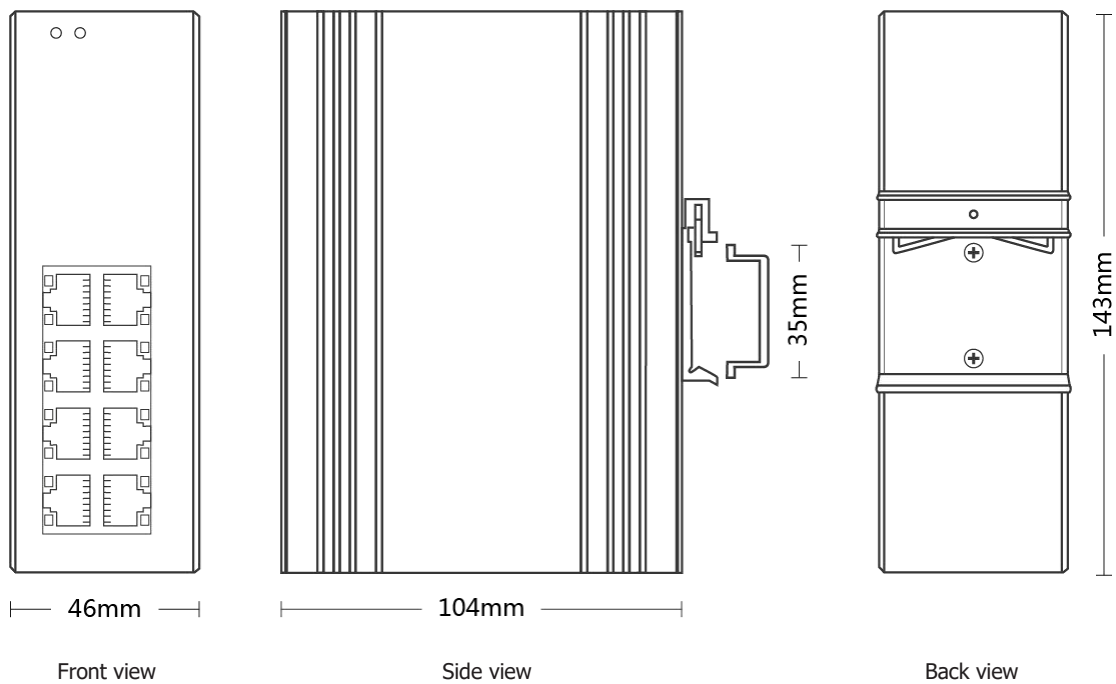

■ Ordering Information

PART NO	DESCRIPTION
LA-IS4N-G0008	8*10/100/1000M RJ45 Port

■ Accessories

PART NO	DESCRIPTION
LA-IS4N-G0008	device, terminals, specification, certificate adapter(optional)