

# LA-IS7M2-G0208

2\*1000Base-X, 8\*10/100/1000Base-T Managed Industrial Ethernet Switch (PoE Optional)

## Highlight Information ▶▶▶▶

LA-XXX/LAM-XXX Series

For LA-XXX Series

For LA-XXX Series



## Introduction

This LA-75V-2GX8GT Industrial Ethernet Switch uses store-forward architecture, fanless and energy-saving design. The advantage of product are small, convenient and easy to maintain. The product design complies with the Ethernet standard, adding lightning protection, anti-static protection measures. It applies to the wide range of operating temperature from  $-40^{\circ}\text{C} \sim +75^{\circ}\text{C}$  with stable and reliable performance.

The device can be widely applied to various broadband data transmission fields such as intelligent transportation, telecommunications, security, financial securities, customs, shipping, power, water conservancy and oil fields.

## Features

- **Input Voltage:** DC10~58V
- **Shell:** IP40 protection, fanless design
- **Anti-static:** 8KV-15KV
- **Operating Temperature:**  $-40^{\circ}\text{C} \sim +75^{\circ}\text{C}$
- **Test Report:** CCC, RoHS, FC, CE, ISO
- **MTBF:** 100000 Hours

## Specification

PART NO	LA-IS7M2-G0208
Provider Mode Ports	
Fixed Port	2*1000 Base-X, 8*10/100/1000 Base-T
Management Port	Support console
Power Interface	Phoenix terminal, redundant dual
LED Indicators	PWR, Link/ACT LED
Cable Type & Transmission Distance	
Twisted-pair	0-100m (CAT5e,CAT6)
Monomode Optical Fiber	20/40/60/80/100KM
Multimode Optical Fiber	550m
Network Topology	
Ring Topology	Support
Star Topology	Support
Bus Topology	Support
Tree Topology	Support
Hybrid Topology	Support
Electrical Specifications	
Input Voltage	DC10-58V
Total Power Consumption	Non PoE <10W, PoE <132W
PoE (Support Optional)	
PoE Port	1-8
PoE Protocol	802.3af, 802.3at
Pin Assignment	1,2,3,6
PoE Management	Support
Layer 2 Switching	
Switching Capacity	40G
Packet Forwarding Rate	26.7Mpps
MAC Address Table	16K
VLAN	Support 4K
Buffer	8M
Forwarding Delay	<10us
MDX/MIDX	Support
Flow Control	Support
Jumbo Frame	10Kbytes
Spanning Tree	Support STP/RSTP/MSTP
Ring Protocol	Support ERPS

Link Aggregation	Support 12 group
Multicast	Support IGMP Snooping
Port Mirroring	Support
Storm Control	Support
Interface Counters	Support
QINQ	Support
<b>Convergence</b>	
ACL	Support ACL 500 Support IP standard ACL Support MAC expand ACL Support IP expand ACL
QoS	Support QoS re-marking, priority mapping Support SP, WRR queue scheduling Support egress rate-limited, egress rate-limit Support Policy-based QoS
<b>Management</b>	
CLI	Support
Console	Support
Telnet	Support
WEB Management	Support
SNMP	Support SNMPv1/v2c
User Management	Support
System Log	Support
Configuration File Download/Upload	Support
Upgrade Firmware	Support
<b>Environment</b>	
Operating Temperature	-40°C~+85°C
Storage Temperature	-40°C~+85°C
Relative Humidity	5%~95% (non-condensing)
Thermal Methods	Fanless, natural cooling
MTBF	100,000 hours
<b>Mechanical Dimensions</b>	
Product Size	143X104X48mm (W×H×D)
Installation Method	DIN-rail
Weight	0.58KG around
<b>EMC &amp; Ingress Protection</b>	
IP Level	IP40
Surge Protection of Power	IEC 61000-4-5 Level 3 (4KV/2KV) (8/20us)
Surge Protection of Ethernet Port	IEC 61000-4-5 Level 3 (4KV/2KV) (10/700us)
RS	IEC 61000-4-3 Level 3 (10V/m)

EFI	IEC 61000-4-4 Level 3 (1V/2V)
CS	IEC 61000-4-6 Level 3 (10V/m)
PFMF	IEC 61000-4-8 Level4 (30A/m)
DIP	IEC 61000-4-11 Level3 (10V)
EMI	CLASS A
ESD	IEC 61000-4-2 Level 4 (8K/15K)
Free Fall	0.5m
Authentication	
Authentication	CCC/CE/FCC/RoHS

## ■ Dimensions

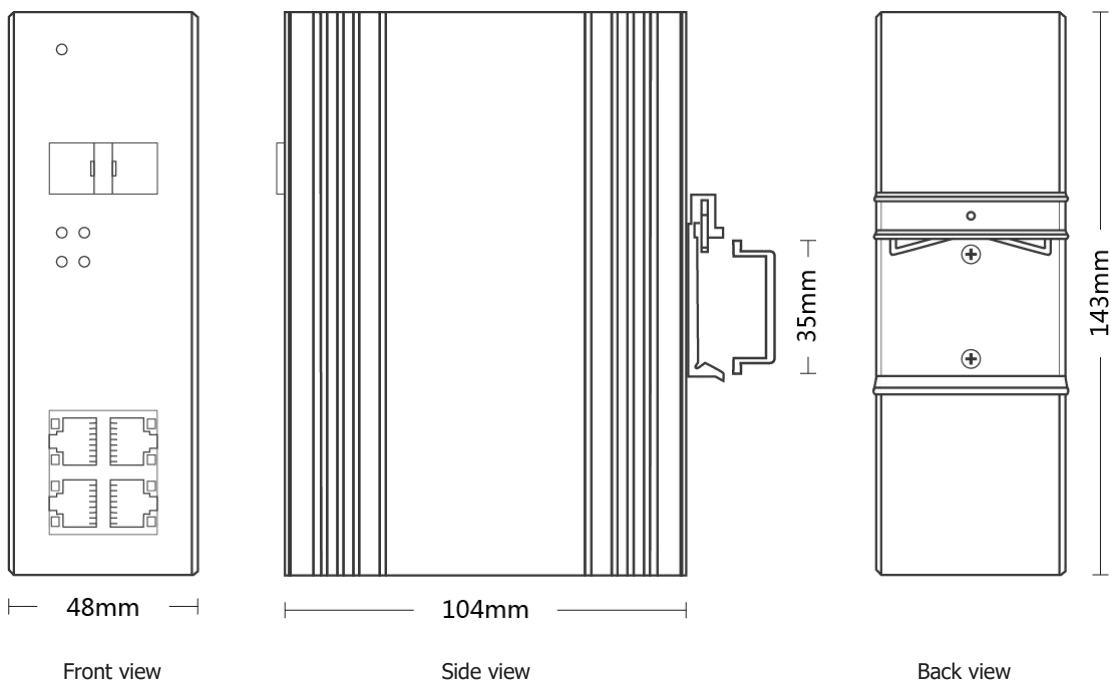

## ■ Ordering Information

PART NO	DESCRIPTION
LA-IS7M2-G0208	2*1000Mbps SFP Port, 8*10/100/1000M RJ45 Port (PoE is optional)

## ■ Accessories

PART NO	DESCRIPTION
LA-IS7M2-G0208	device, terminals, specification, certificate adapter(optional)