

LA-IS8M2RLB-G0208(P)-Z

Industrial L2+ Managed Switch 2x1000M SFP, 8x10/100/1000M RJ45



Overview

LA-IS8M2RLB-G0208(P)-Z is a managed industrial Ethernet fast switch featuring 2 Gigabit SFP ports and 8x 10/100/1000Base-T ports. Designed with a fan-less heat dissipation circuit, wide operating temperature range, and high protection grade, it delivers excellent industrial-grade performance, including resistance to extreme temperatures and lightning. Supporting rich switching and security protocols along with Ethernet Ring Protection Switching (ERPS), it enhances network flexibility, reliability, and security. Ideal for applications in rail transit, safe city projects, intelligent transportation, outdoor surveillance, and other demanding environments.

Features

- Input voltage: DC12-58V
- Operating temperature: -40°C ~ +85°C
- Casing: IP50 protection level, fan-less design
- Inspection report: CE/FCC/RoHS
- Anti-static: 8KV-15KV
- MTBF: 100000 hours

Specifications

Provided Ports

Fixed Port	2*1000Base-X, 8*10/100/1000Base-T
Management Port	Support console
Power Interface	Phoenix terminal, redundant dual power supply
LED Indicators	PWR, Link/ACT LED

Cable Type & Transmission Distance

Twisted-pair	0-100m (CAT5e, CAT6)
Mono Mode Optical Fiber	20/40/60/80/100KM
Multi-mode Optical Fiber	550m

Network Topology

Ring Topology	Support
Star Topology	Support
Bus Topology	Support
Tree Topology	Support
Hybrid Topology	Support

Electrical Specifications

Input Voltage	DC12-58V(non-PoE)/ DC48-58V(PoE)
Total Power Consumption	<10W(non-PoE), <250W(PoE)

PoE/PoE+

PoE Port	1-8
PoE Protocol	802.3af, 802.3at
Pin Assignment	1, 2+, 3, 6-
PoE Management	Support

PoE++ Optional

PoE Port	1-2
PoE Protocol	802.3bt (PoE++ BT 90W)
Pin Assignment	1, 2, 4, 5+, 3, 6, 7, 8-
PoE Management	Support

Layer 2 Switching

Switching Capacity	36G
--------------------	-----

Packet Forwarding Rate	26.78Mpps
MAC Address Table	16K
VLAN	Support 4K
Buffer	12M
Forwarding Delay	<10us
MDX/MIDX	Support
Flow Control	Support
Jumbo Frame	Support 10Kbytes
Spanning Tree	Support STP/RSTP/MSTP
Ring Protocol	Support ERPS
Link Aggregation	Support 64 group
Multicast	Support IGMP Snooping
Port Mirroring	Support
Storm Control	Support
Interface Counters	Support
QINQ	Support
802.1X	Support
MAC Authentication	Support
Port Isolation	Support
LLDP	Support
Ramon	Support
NTP Client	Support
DHCP Client	Support
DHCP Snooping	Support
PING/Tracert Detection	Support
Dying gasp	Support
DDM	Support
Port Security	Support
IP Source Guard	Support
Device Scanning	Support

Layer 3 Route

IPv4 /IPv6 Static Routing	Support 256 static routes.
ARP	ARP Table Entry Aging
DHCP server	Support
Convergence	
ACL	Support ACL 240 Support IP standard ACL/ACLv6 Support MAC expand ACL/ACLv6 Support IP expand ACL/ACLv6
QOS	Support QoS re-marking, priority mapping Support SP, WRR queue scheduling Support egress rate-limited, egress rate-limit Support Policy-based QoS
D dos Attack	Support
Management	
CLI	Support
Console	Support
Telnet	Support
WEB Management	Support
Management IP	Support IPV4/IPV6
SNMP	Support SNMPv1/v2c/v3
User Management	Support
System Log	Support
Configuration File Download/Upload	Support
Upgrade Firmware	Support
Environment	
Operating Temperature	-40°C~+85°C
Storage Temperature	-40°C~+85°C
Relative Humidity	5%~95% (non-condensing)
Thermal Methods	Fan-less design
MTBF	100,000 hours
Mechanical Dimensions	
Product Size	143x104x65mm
Installation Method	DIN-rail
Weight	0.85KG

EMC & Ingress protection

IP Level	IP50
Surge Protection of Power	IEC 61000-4-5 Level X(10KV/10KV) (8/20us)
Surge Protection of Ethernet Port	IEC 61000-4-5 Level X(6KV/4KV) (10/700us)
RS	IEC 61000-4-3 Level 3(10V/m)
EFI	IEC 61000-4-4 Level 3(1V/2V)
CS	IEC 61000-4-6 Level 3(10V/m)
PFMF	IEC 61000-4-8 Level 4(30A/m)
DIP	IEC 61000-4-11 Level 3(10V)
ESD	IEC 61000-4-2 Level 4(8K/15K)
Free Fall	0.5m

Certification

Certificates	CE/FCC/RoHS
--------------	-------------

Dimension

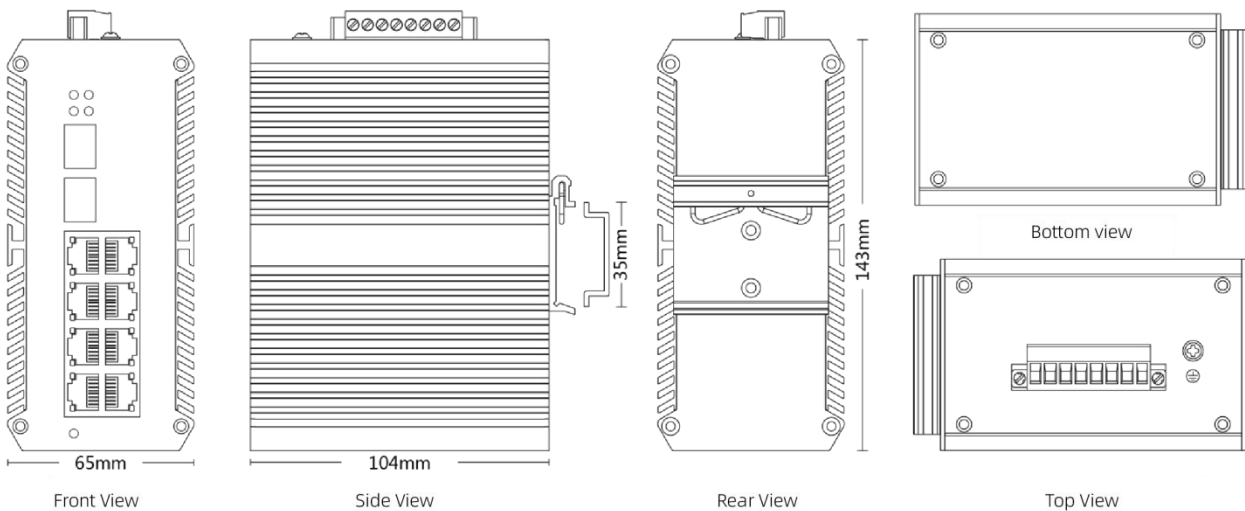

Ordering Information

PART NO	DESCRIPTION
LA-IS8M2RLB-G0208P-Z	Industrial L2+ Managed PoE Switch 2x1000M SFP, 8x10/100/1000M RJ45 PoE
LA-IS8M2RLB-G0208-Z	Industrial L2+ Managed Ethernet Switch 2x1000M SFP, 8x10/100/1000M RJ45
LA-IS8M2RLB-G0208PB-Z	Industrial L2+ Managed PoE++ Switch 2x1000M SFP, 8x10/100/1000M RJ45 PoE (Port 1-2 Max. BT90W)



<https://www.lanaotek.com>



Specifications & design are subject to change without prior notice.

For more details, please email to info@lanaotek.com. Copyright©2023 lanaotek.com All Rights Reserved