

10Gb/s Tunable DWDM XFP 80km Transceiver

LA-OT-10GTDW-X80

Description

The tunable 10 Gb/s XFP transceiver is an integrated fiber optic transceiver that provides a high-speed serial link at signaling rates from 9.95 Gb/s to 11.35 Gb/s. The module complies with the 10 Gigabit small form factor pluggable (XFP) multisource agreement-MSA (INF-8077i) and Tunable XFP for ITU Frequency Grid Applications (SFF-8477) .

It complies with the ITU-T G.698.1 standard with 50 GHz channel spacing for SONET/SDH, IEEE DWDM 10GBASE-ZR for 80 km reach (Ethernet), and DWDM 10GFC for 80 km reach (Fiber Channel) applications.

The transceiver integrates the receiver and transmit path on one module. On the transmit side, the 10 Gbps serial data stream is recovered, retimed, and passed to a modulator driver. The modulator driver biases and modulates a C-band-tunable integrated laser Mach-Zehnder (ILMZ), enabling data transmission over single-mode fiber through an industry-standard LC connector. On the receiver side, the 10 Gbps data stream is recovered from an APD/trans-impedance amplifier, retimed, and passed to an output driver. This module features a hot-pluggable XFI-compliant electrical interface.

Features

- Supports 9.95Gb/s to 11.3Gb/s bit rates
- Monolithically integrated full C-band tunable transmitter
- 50 GHz ITU channel spacing with integrated wavelength locker
- C-band-tunable Laser and APD receiver
- Maximum link length of 80km
- Full Duplex LC connector
- Hot-pluggable XFP footprint
- Supports Line-side and XFI loopback
- No Reference Clock required
- Built-in digital diagnostic functions
- Standard bail release mechanism
- Power dissipation <3.5W
- Case temperature range:0°C to 70°C

Application

- DWDM 10GBASE-ZR/ZW 10G Ethernet
- DWDM 80KM 10G Fiber Channel
- DWDM SONET OC-192&SDH STM-64

LA-OT-10GTDW-X80 Wavelength Guide Pin Descriptions

Channel	Wavelength(nm)	Frequency (THZ)	Channel	Wavelength (nm)	Frequency (THZ)
			44	1546.12	193.9
1	1563.45	191.75	45	1545.72	193.95
2	1563.05	191.8	46	1545.32	194
3	1562.64	191.85	47	1544.92	194.05
4	1562.23	191.9	48	1544.53	194.1
5	1561.83	191.95	49	1544.13	194.15
6	1561.42	192	50	1543.73	194.2
7	1561.01	192.05	51	1543.33	194.25
8	1560.61	192.1	52	1542.94	194.3
9	1560.2	192.15	53	1542.54	194.35
10	1559.79	192.2	54	1542.14	194.4
11	1559.39	192.25	55	1541.75	194.45
12	1558.98	192.3	56	1541.35	194.5
13	1558.58	192.35	57	1540.95	194.55
14	1558.17	192.4	58	1540.56	194.6
15	1557.77	192.45	59	1540.16	194.65
16	1557.36	192.5	60	1539.77	194.7
17	1556.96	192.55	61	1539.37	194.75
18	1556.55	192.6	62	1538.98	194.8
19	1556.15	192.65	63	1538.58	194.85
20	1555.75	192.7	64	1538.19	194.9
21	1555.34	192.75	65	1537.79	194.95
22	1554.94	192.8	66	1537.4	195
23	1554.54	192.85	67	1537	195.05
24	1554.13	192.9	68	1536.61	195.1
25	1553.73	192.95	69	1536.22	195.15
26	1553.33	193	70	1535.82	195.2
27	1552.93	193.05	71	1535.43	195.25
28	1552.52	193.1	72	1535.04	195.3
29	1552.12	193.15	73	1534.64	195.35
30	1551.72	193.2	74	1534.25	195.4
31	1551.32	193.25	75	1533.86	195.45
32	1550.92	193.3	76	1533.47	195.5
33	1550.52	193.35	77	1533.07	195.55
34	1550.12	193.4	78	1532.68	195.6
35	1549.72	193.45	79	1532.29	195.65
36	1549.32	193.5	80	1531.9	195.7
37	1548.91	193.55	81	1531.51	195.75
38	1548.51	193.6	82	1531.12	195.8
39	1548.11	193.65	83	1530.72	195.85

40	1547.72	193.7	84	1530.33	195.9
41	1547.32	193.75	85	1529.94	195.95
42	1546.92	193.8	86	1529.55	196
43	1546.52	193.85	87	1529.16	196.05
Non-ITU	Peak wavelength between 1528.77nm-1563.45nm		88	1528.77	196.1

Note:

1. When a tunable module is plugged in for the first time, it will go to a default channel, or Tx_DIS asserted it will go to a standby condition. LA-OT-10GTDW-X80 default channel is 1563.45nm, compatible with channel range from 1 to 88.
2. When the module is power cycled it will automatically go to the last channel selected, or Tx_DIS asserted it will go to a standby condition. If Tx_DIS asserted, the last channel selected will be cleared, and a valid new channel command will be required to set a channel.
3. If the Tx disabled and then re-enabled, the module returns to the last channel selected.

Absolute Maximum Ratings

Parameter	Symbol	Min	Typ	Max	Unit	Note
Maximum Supply Voltage 1	Vcc3	-0.5		4.0	V	
Maximum Supply Voltage 2	Vcc5	-0.5		6.0	V	
Storage Temperature	TS	-40		85	°C	
Case Operating Temperature	Tcase	0		70	°C	

Electrical Characteristics

Parameter	Symbol	Min	Typ	Max	Unit	Note
Main Supply Voltage	Vcc5	4.75		5.25	V	
Supply Voltage #2	Vcc3	3.13		3.45	V	
Supply Current – Vcc5 supply	Icc5			350	mA	
Supply Current – Vcc3 supply	Icc3			450	mA	
Module total power	P			3.5	W	1
Transmitter						
Input differential impedance	Rin		100		Ω	2
Differential data input swing	Vin,pp	120		820	mV	
Transmit Disable Voltage	VD	2.0		Vcc	V	
Transmit Enable Voltage	VEN	GND		GND+ 0.8	V	

Receiver						
Differential data output swing	Vout,pp	340	650	850	mV	3
LOS Fault	VLOS fault	Vcc – 0.5		VccHOST	V	4
LOS Normal	VLOS norm	GND		GND+0.5	V	4

Notes:

1. Maximum total power value is specified across the full temperature and voltage range.
2. After internal AC coupling.
3. Into 100 ohms differential termination.
4. Loss Of Signal is open collector to be pulled up with a 4.7k – 10kohm resistor to 3.15 – 3.6V. Logic 0 indicates normal operation; logic 1 indicates no signal detected.

Optical Characteristics

Parameter	Symbol	Min	Typ	Max	Unit	Note
Transmitter						
Average Optical Power	Pf	-1		3	dBm	
Wavelength range		1528.77		1563.45	nm	LA-OT-10GTDW-X80
Optical Wavelength	λ_c	$\lambda_c - 0.05$		$\lambda_c + 0.05$	nm	
Center Wavelength Spacing			50		GHz	1
Frequency stability (BOL)		-1.5		1.5	GHz	
Frequency stability (EOL)		-2.5		2.5	GHz	
Side mode Suppression ratio	SMSR	30			dB	
Optical Extinction Ratio	ER	9			dB	
Transmitter and Dispersion Penalty	TDP			3	dB	
Average Launch power of OFF transmitter	POFF			-30	dBm	
Receiver						
Rx Sensitivity	RSENS			-24	dBm	Back-to-back ,2
				-21.5		Fiber (-300 to 1450ps/nm)
Input Saturation Power (Overload)	Psat	-7			dBm	
Wavelength Range	λ_c	1260		1600	nm	
Receiver Reflectance	Rrx			-27	dB	
LOS De-Assert	LOSD			-27	dBm	
LOS Assert	LOSA	-37			dBm	
LOS Hysteresis		0.5			dB	

Notes:

1. Corresponds to approximately 0.4 nm.
2. Measured with worst ER; BER < 10^{-12} with 10.3Gbps, $2^{31} - 1$ PRBS.

Pin Assignment

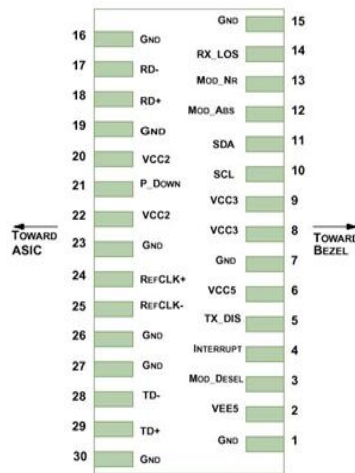

Diagram of Host Board Connector Block Pin Numbers and Name

Pin	Logic	Symbol	Name/Description	Note
1		GND	Module Ground	1
2		VEE5	Optional -5.2 Power Supply – Not required	
3	LVTTL-I	Mod-Desel	Module De-select; When held low allows the module to respond to 2-wire serial interface commands	
4	LVTTL-O	Interrupt	Interrupt (bar); Indicates presence of an important condition which can be read over the serial 2-wire interface	2
5	LVTTL-I	TX_DIS	Transmitter Disable; Transmitter laser source turned off	
6		VCC5	+5 Power Supply	
7		GND	Module Ground	1
8		VCC3	+3.3V Power Supply	
9		VCC3	+3.3V Power Supply	
10	LVTTL-I	SCL	Serial 2-wire interface clock	2
11	LVTTLI/O	SDA	Serial 2-wire interface data line	2
12	LVTTL-O	Mod_Abs	Module Absent; Indicates module is not present. Grounded in the module.	2
13	LVTTL-O	Mod_NR	Module Not Ready; Lanbras defines it as a logical OR between RX_LOS and Loss of Lock in TX/RX.	2
14	LVTTL-O	RX_LOS	Receiver Loss of Signal indicator	2
15		GND	Module Ground	1
16		GND	Module Ground	1
17	CML-O	RD-	Receiver inverted data output	
18	CML-O	RD+	Receiver non-inverted data output	
19		GND	Module Ground	1
20		VCC2	+1.8V Power Supply – Not required	
21	LVTTL-I	P_Down/RST	Power Down; When high, places the module in the low power stand-by mode and on the falling edge of P_Down initiates a module reset	

			Reset; The falling edge initiates a complete reset of the module including the 2-wire serial interface, equivalent to a power cycle.	
22		VCC2	+1.8V Power Supply – Not required	
23		GND	Module Ground	1
24	PECL-I	RefCLK+	Reference Clock non-inverted input, AC coupled on the host board – Not required	3
25	PECL-I	RefCLK-	Reference Clock inverted input, AC coupled on the host board – Not required	3
26		GND	Module Ground	1
27		GND	Module Ground	1
28	CML-I	TD-	Transmitter inverted data input	
29	CML-I	TD+	Transmitter non-inverted data input	
30		GND	Module Ground	1

Notes:

1. Module circuit ground is isolated from module chassis ground within the module.
2. 2 Open collector; should be pulled up with 4.7k – 10kohms on host board to a voltage between 3.15V and 3.6V.
3. A Reference Clock input is not required by the XFP 80km tunable. If present, it will be ignored.

Digital Diagnostic Functions

XFP 80km tunable transceivers provide digital diagnostic functions via a 2-wire serial interface, which allows real-time access to the following operating parameters:

- Transceiver temperature
- Laser bias current
- Transmitted optical power
- Received optical power
- Transceiver supply voltage

It also provides a sophisticated system of alarm and warning flags, which may be used to alert end-users when particular operating parameters are outside of a factory-set normal range.

The operating and diagnostics information is monitored and reported by a Digital Diagnostics Transceiver Controller inside the transceiver, which is accessed through the 2-wire serial interface. When the serial protocol is activated, the serial clock signal (SCL pin) is generated by the host. The positive edge clocks data into the XFP transceiver into those segments of its memory map that are not write-protected. The negative edge clocks data from the XFP transceiver. The serial data signal (SDA pin) is bi-directional for serial data transfer. The host uses SDA in conjunction with SCL to mark the start and end of serial protocol activation. The memories are organized as a series of 8-bit data words that can be addressed individually or sequentially. The 2-wire serial interface provides sequential or random access to the 8-bit parameters, addressed from 000h to the maximum address of the memory.

For more detailed information including memory map definitions, please see the XFP Specification.

Outline Drawing (mm)

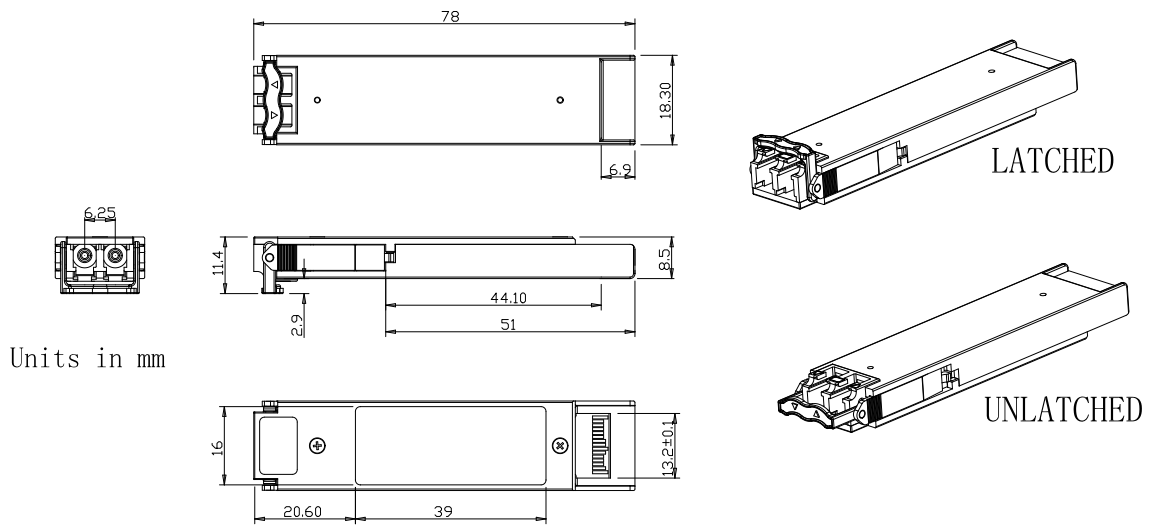



<https://www.lanaotek.com>



Specifications & design are subject to change without prior notice.

For more details, please email to info@lanaotek.com. Copyright©2024 lanaotek.com All Rights Reserved